

Cover It! Lab

Date Submitted:

Your Name:

Question/Problem: To make a book cover that is identical to those produced by the rest of class to assure that the textbook is protected throughout the year.

Hypothesis:

Materials:

Large Brown Paper Grocery Sack

Pencil

Scissors

Tape

Metric Ruler

Markers

Procedure

1. Using the scissors, cut down one corner of the grocery bag to the bottom.
2. Cut around the four edges of the bottom of the bag and remove.
3. Lay the brown bag out flat on the tabletop.
4. Using a metric ruler and a pencil, measure out and draw a rectangle 90cm wide and 40 cm high.
5. Cut out the rectangle.
6. With the printed side of the bag facing up, draw a line parallel to each long side of the rectangle that is 5.6 cm from the edge.
7. Draw lines parallel to each of the shorter sides that is 21 cm from the edge.
8. Fold the edges in along the lines drawn for each of the long sides.
9. Fold the edges in along the lines drawn for each of the shorter sides.
10. Slide each side of the book into the book cover. Seal the edges with scotch tape. (DO NOT TAPE THE COVER DIRECTLY TO THE TEXT.)
11. Write your name and your teacher's name on the inside flap of your new book cover.
12. Using the markers, label your cover down the spine and on the front "Chemistry"

Observations

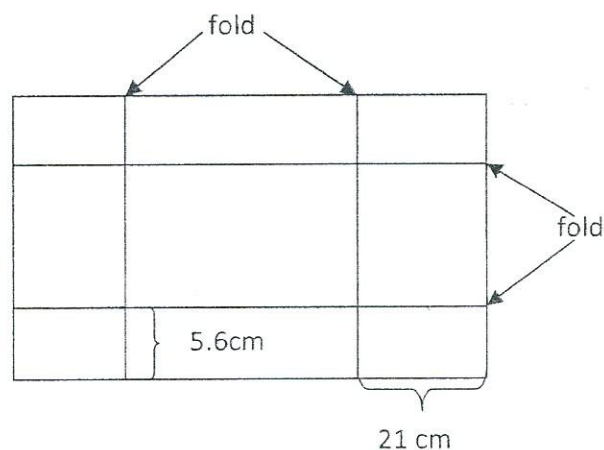
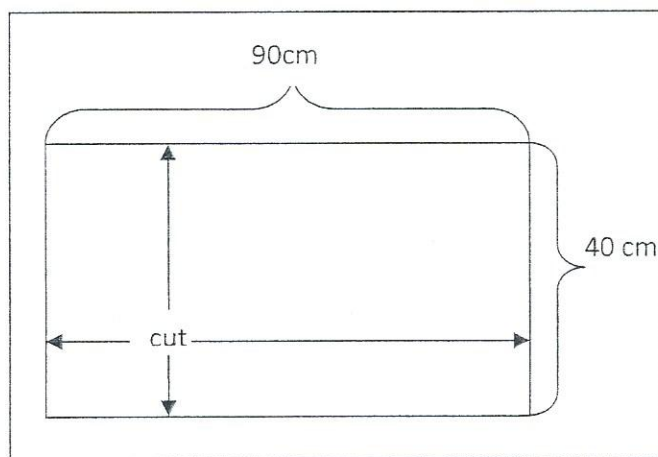

Conclusion: